

Festoon systems for cables and hoses





AKAPP Festoon installation with flat cables at a water purification plant

Components

An AKAPP festoon installation contains the following components:

- A. track (C-profile)
- B. support bracket
- C. splice joint
- D. end stop
- E. end clamp
- F. cable trolley
- G. towing trolley, or
- H. mobile pendant
(not on illustration)

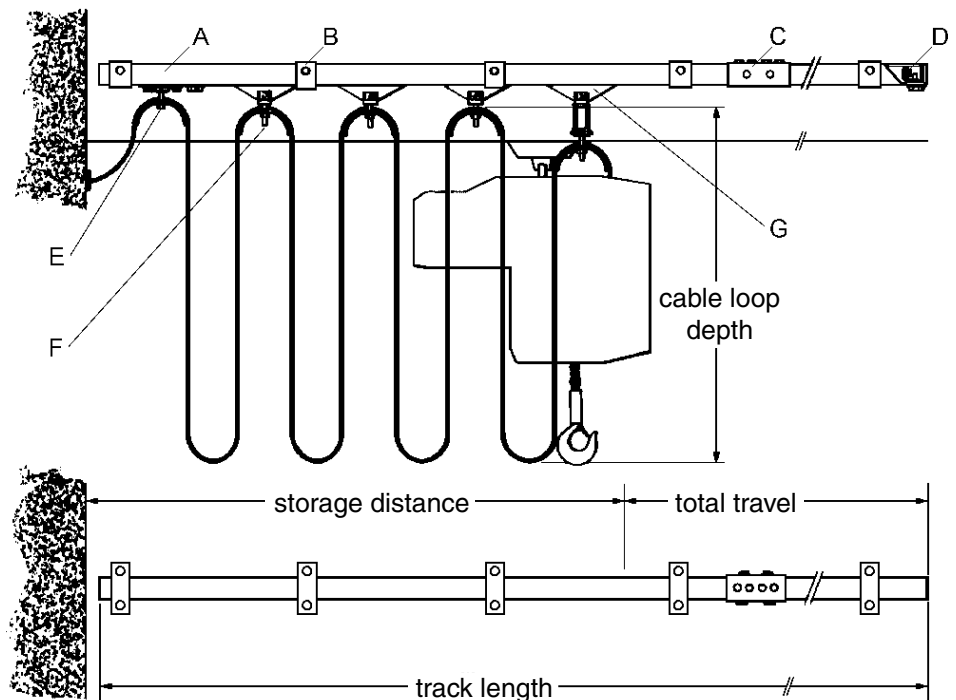

Diagram of an AKAPP festoon installation.

AKAPP Festoon systems, for cables and hoses

Safe, effective and economical means of transporting feeding and control cables and hoses:

- uninterrupted electrical feeding and control of all movable apparatus such as cranes, hoists and many other apparatus for internal transport, machines or tools.
- uninterrupted supply of gasses and/or liquids to movable machines or tools e.g. welding and cutting machines, pressure air and hydraulic systems, washing and sprinkler installations.

AKAPP Festoon systems are used in many applications world-wide, indoors and outdoors, under the most divergent environmental conditions.

Wabtec Netherlands, specialist in movable power supply systems, takes a leading position, also in the field of festoon systems. We offer you a wide range of options and high-quality components, focussing on maximum efficiency.

Which advantages does AKAPP Festoon systems offer you?

- **Optimal reliability**
due to the solid construction and effective shape of all components.
- **Longer life cycle of your cables and hoses**
AKAPP Festoon systems let your cables and hoses move smoothly, without twisting and tangling.
- **Safe**
Your cables and hoses are neatly stored, which prevent dangerous situations on the work floor, e.g. workshops.
- **Easy and fast mounting**
- **Practically no maintenance**
AKAPP C-profile prevents inconvenient deposition of moisture and dirt on the running surface.
- **Easy to extend**
- **Solid construction**
All components of an AKAPP Festoon system are made of high-quality materials. We offer you the best possible solutions for your applications.
- **Seamless profile connections**
The profile sections can be connected exactly in line by means of adjustment bolts.

Performances

AKAPP Festoon systems are available in many performances and sizes.

Distinguished are following systems:

- **C-profile**, in which the trolleys run. This system is used in many applications indoors and outdoors. Cost-effective and easy to install.
- **Square tube** is a special shaped profile. The trolleys run over the tube, with running wheels around it. Very suitable for installations with horizontal or vertical curves, without the need for guiding rails.

C-profile

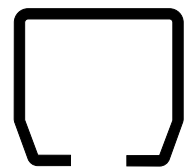

Square tube profile

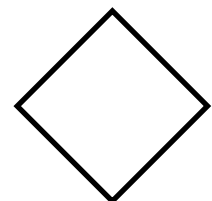

Dimensions and weights of AKAPP C-profiles

Available C-profile types R150, R300, R400, R500 and R600. Standard lengths of profile R150 and R300 is 4 metre. Standard length of profiles R400, R500 and R600 is 6 metre.

The special shape of the profile guarantees smooth running of the cable trolleys. Therefore, mechanical resistance and wear of the trolleys remains low.

The profiles can also be used for outdoor applications or under dusty and humid conditions. The wheels of the trolleys clean the surface while running on it, so there's no gathering of dust etc..

The C-profiles are also available in stainless steel, for aggressive environments. Our sales department can advise you.

See the dimension table (right) for all relevant sizes and capacities. Please note that the carrying capacities are valid only when the support distance is ≤ 1 metre.

Profile type and travelling speed

Following maximum travelling speeds count for straight tracks:

C-Profile	Max. speed (m/min)
R150	60
R300	120
R400	180
R500/R600	>180

For travelling speeds from 120 m/min. it is recommended to use chains between the cable trolleys. This prevents that too much pulling force will damage the cables or hoses.

Festoon installations with curves

The C-profiles as mentioned above can be used in installation with curved tracks. However a special guiding rail is needed for proper guiding of the cable trolleys. See the drawing on the right.

It is recommended to use **quadrantube** profiles for these applications. Due to the shape and the characteristics of this profile, the trolleys will run perfectly without special arrangement.

Please contact us for further information on this.

Calculating an AKAPP Festoon installation

It is necessary to obtain all relevant details of the environment to configure the best possible festoon installation.

Wabtec Netherlands B.V. can advise you further! We developed a questionnaire for this purpose. Once you answered the questions on that form, just send it to us and we will make a quotation for you.

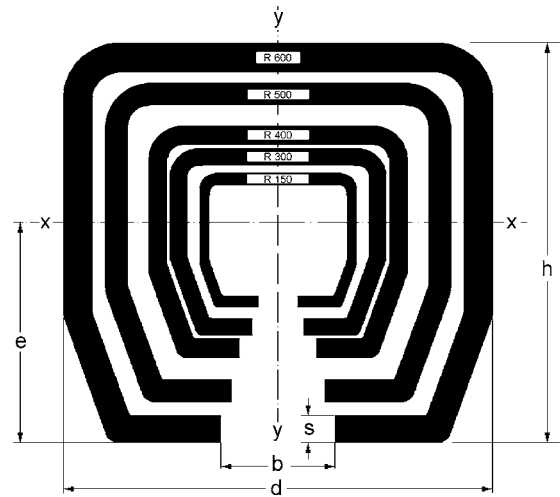

	C-Profile				
	R150	R300	R400	R500	R600
h (mm)	28	35	43,5	60	75
d (mm)	30,5	40	48,5	65	80
s (mm)	2	2,7	3,2	3,6	4,5
b (mm)	10,5	10	15	18	22
e (mm)	14,5	19,5	24,8	33,8	41,9
W (kg/m)	1,3	2,7	3,6	5,7	8,9
F (kg/m)	80	100	200	500	1000

W = Weight
F = Carrying capacity (with supports every 1 metre)

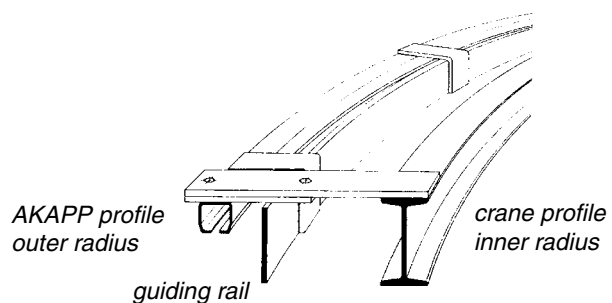

The mounting of a festoon installation is simple. But of course, we can do this for you! We will be happy to make you an offer on this.

This implies less preparation for you and maximum reliability!

Please note that Wabtec Netherlands B.V. has a wide program of high-flexible cables, suitable for every festoon system!

AKAPP C-profile and components

The AKAPP C-profile is available in many sizes and performances, making it suitable for practically every circumstance, regarding load capacity and environment.

Profile types R150 and R300 are standard made of zinc plated steel.

Profile types R400, R500 and R600 are dichromated.

The dichromating process improves the quality of the zinc plating, which results in better resistance against corrosion.

Special performances of the components as mentioned here are:

- stainless steel;
- blank steel;
- dichromated steel (profile R150 and R300).

Profile type R

Type	R150	R300	R400	R500	R600
h (mm)	28	35	43,5	60	75
d (mm)	30,5	40	48,5	65	80
b (mm)	10,5	10	15	18	22
s (mm)	2	2	3,2	3,6	4,5
W* (kg/m)	1,3	1,9	3,6	5,7	8,9
F* (kg/m)	80	100	200	500	1000
L* (m)	4	4	6	6	6

W=weight F=carrying capacity with support
L=standard length distance max. every 1 m

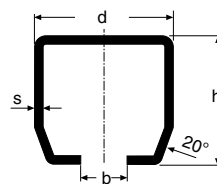

Ceiling support bracket type PM

Material : galvanised and dichromated steel
Mounting : by 2 bolts M8

Type	PM150	PM300	PM400	PM500	PM600
b (mm)	90	115	130	170	210
d (mm)	8,2	11	13	17	22
h (mm)	39	50	59	81	104
j (mm)	40	50	60	80	100
m (mm)	7	8	8	10	12
n (mm)	56	72	86	114	136
s (mm)	3	4	4,5	6	8
weight (kg)	0,2	0,4	0,6	1,5	2,9

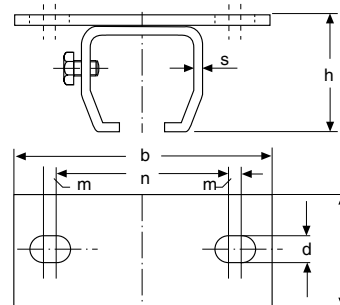

Wall support bracket type WM

Material : galvanised and dichromated steel
Mounting : by 1 bolt M8

Type	WM150	WM300	WM400	WM500	WM600
b (mm)	38	50	60	80	100
d (mm)	8	11	13	17	22
h (mm)	60	76	94	123	157
L (mm)	40	55	68	90	110
n (mm)	10	13	16,5	18	25
s (mm)	3	4	4,5	6	8
weight (kg)	0,15	0,35	0,45	1,4	2,5

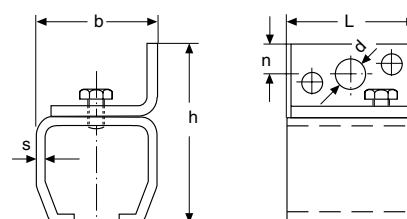

Hang joint type OM

Material : galvanised and dichromated steel
 Mounting : by 1 bolt M10x30

Type	OM150	OM300	OM400	OM500	OM600
b (mm)	36	48	56,5	77	96
e (mm)	20	24	24	32	32
h (mm)	72,5	88,5	97	131	152
l (mm)	40	55	68	90	110
g (mm)	6	8	8	10	10
f (mm)	17	20	20	25	26
s (mm)	3	4	4,5	6	8
weight (kg)	0,3	0,4	0,45	1,3	2,4

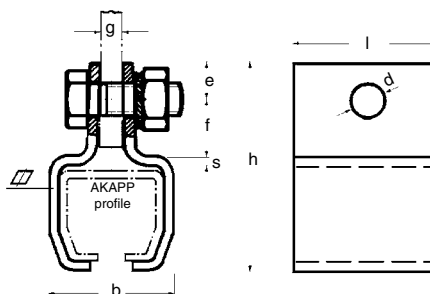

Welding joint type LM

Material : blank steel
 Mounting : welding to construction part

Type	LM150	LM300	LM400	LM500	LM600
b (mm)	38	49	60	80	100
h (mm)	36	45	54	75	94
l (mm)	40	55	68	90	110
s (mm)	3	4	4,5	6	8
weight (kg)	0,14	0,3	0,4	1	2,1

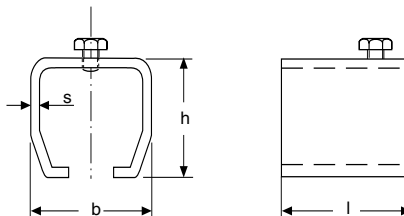

Splice joint type RV

Material : galvanised and dichromated steel

Type	RV150	RV300	RV400	RV500	RV600
b (mm)	38	50	60	80	100
h (mm)	39	45	54	75	94
l (mm)	100	120	150	180	200
s (mm)	3	4	4,5	6	8
weight (kg)	0,3	0,6	1	2,1	3,8

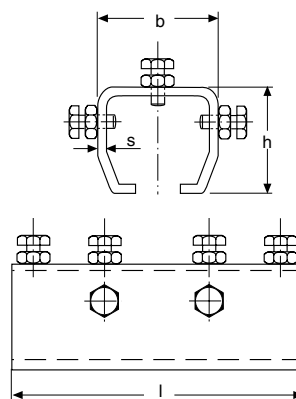

End stop RS

Material : galvanised and dichromated steel
 and rubber buffer

Type	RS150	RS300	RS400	RS500	RS600
a (mm)	25	30	35	50	125
b (mm)	26	32	39	54	50
c (mm)	23	27	34	50	60
d (mm)	M 8	M 10	M 10	M 12	2x M16
weight (kg)	0,05	0,09	0,12	0,25	1,1

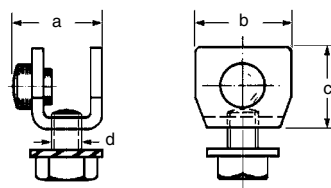

Cable trolleys (Nylon), for profile R150

For flat cables

These AKAPP light duty cable trolleys offer an economic and reliable transport for your cables, with extremely low maintenance!
The synthetic running wheels offer low-noise performance.
For in- and outdoors applications.



Flat cable trolley KVN150

Material : chassis and cable carrier nylon
running wheels polyacetal (POM)
axes galvanised steel

Weight : 0,1 kg

Cable dimensions : 60 x 20 mm max.

Max. cable weight : 6 kg

Travelling speed : 30 m/min. max.

Temperatures : min. -10, max. +85 °C

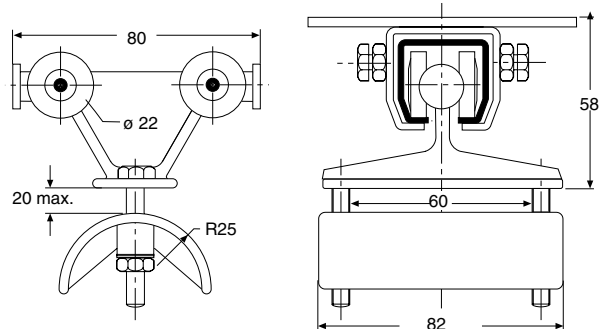

Flat cable towing trolley MVN150

Material : chassis and cable carrier nylon
running wheels polyacetal (POM)
axes galvanised steel

Weight : 0,175 kg

Cable dimensions : 60 x 20 mm max.

Max. cable weight : 6 kg

Travelling speed : 30 m/min. max.

Temperatures : min. -10, max. +85 °C

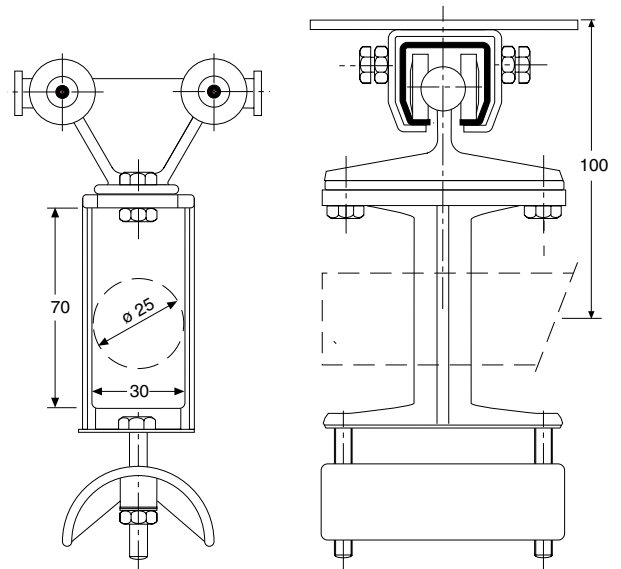

On request, bolts and axes can be supplied in stainless steel. roestvast staal. Axes can also be supplied in bronze.

Cable trolleys (aluminium), for profile R150

For flat cables

AKAPP aluminium cable trolleys for track profile R150 are especially suitable for light duty operation, for both in- and outdoor conditions. The steel wheels are ball beared. The trolleys therefore will roll perfectly smooth through the track profile. The trolleys are equipped with a rubber strip to press against the cable(s).



End clamp AVK150

Material : galvanised steel mounting plate and cable carrier
 Weight : 0,253 kg/m
 Cable dimensions : 58x20 mm max.
 Max. cable weight : 20 kg
 Temperatures : min. - 5 °C, max. 105 °C

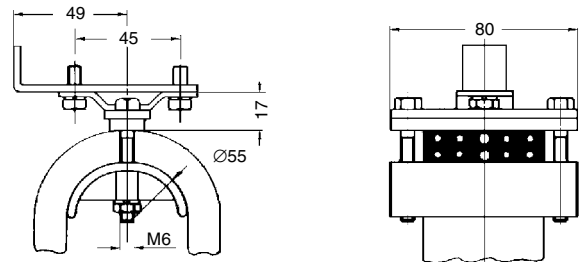

Flat cable trolley KVK150

Material : galvanised steel mounting plate and cable carrier
 Weight : 0,259 kg/m
 Cable dimensions : 58x20 mm max.
 Max. cable weight : 20 kg
 Travelling speed : 60 m/min.
 Temperatures : min. - 5 °C, max. 105 °C

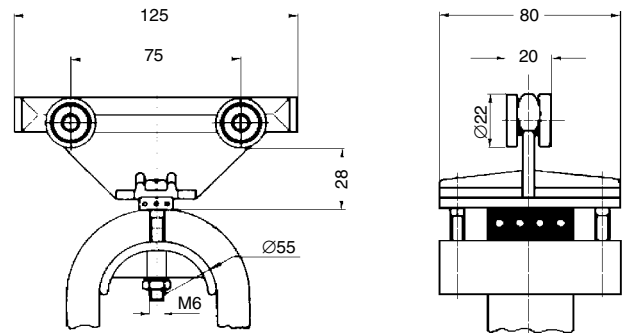

Flat cable towing trolley MVK150

Material : galvanised steel mounting plate and cable carrier
 Weight : 0,537 kg/m
 Cable dimensions : 58x20 mm max.
 Max. cable weight : 20 kg
 Travelling speed : 60 m/min.
 Temperatures : min. - 5 °C, max. 105 °C

(see also photo on top)

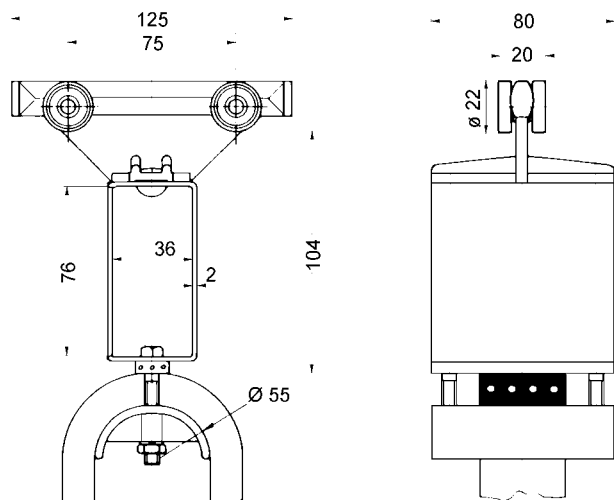

Cable trolleys (steel), for profile R150

For flat cables

AKAPP steel cable trolleys for track profile R150 are especially suitable for light duty operation, for both in- and outdoor conditions. The steel wheels are ball beared. The trolleys therefore will roll perfectly smooth through the track profile. The trolleys are equipped with a rubber strip to press against the cable(s).



End clamp AVK150

Material : galvanised steel mounting plate and cable carrier
 Weight : 0,253 kg
 Cable dimensions : 58 x 20 mm
 Max. cable weight : 20 kg
 Temperatures : min. -5 °C, max. +105 °C

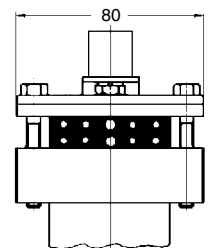
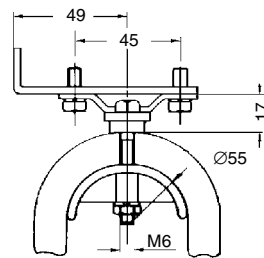

Flat cable trolley KVS150G

Material : galvanised steel mounting plate and cable carrier
 Wheels : steel, ball beared
 Weight : 0,253 kg
 Cable dimensions : 58 x 20 mm max.
 Max. cable weight : 20 kg
 Travelling speed : 60 m/min max.
 Temperatures : min. -5 °C, max. +105 °C

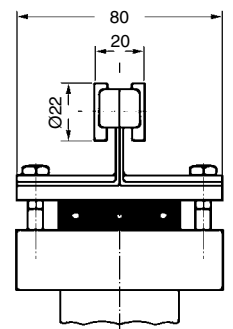
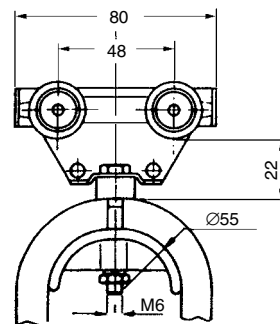

Flat cable towing trolley MVS150G

Material : galvanised steel mounting plate and cable carrier
 Wheels : steel, ball beared
 Weight : 0,422 kg
 Cable dimensions : 58 x 20 mm max.
 Max. cable weight : 20 kg
 Travelling speed : 60 m/min. max.
 Temperatures : min. -5 °C, max. +105 °C

(see photo on top)

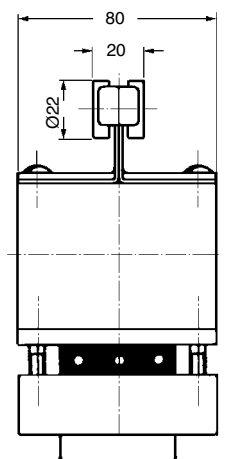
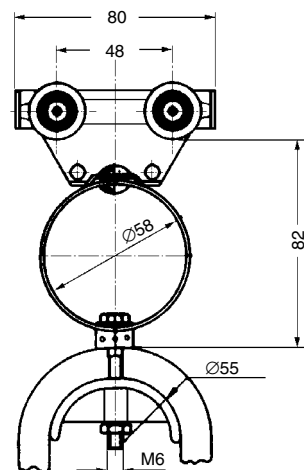

Cable trolleys (steel), for profile R150

For flat cables

These AKAPP cable trolleys are applicable for light duty operation, for both in- and outdoor conditions. All steel parts are dichromatised, which ensures a long life protection.

The high quality steel wheels are double ball beared and have anti dust sealing. The wheels are especially lubricated for a high temperature range.



End clamp AVS150

Material : galvanised and dichromated steel
Weight : 0,3 kg
Cable dimensions : 55 x 20 mm
Max. cable weight : 10 kg
Temperatures : min. - 15 °C, max. 180 °C

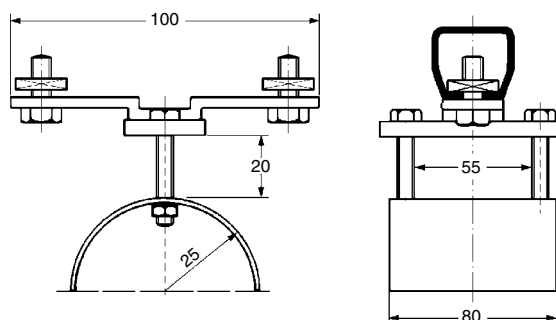

Flat cable trolley KVS150

Material : galvanised and dichromated steel
Weight : 0,4 kg
Cable dimensions : 55 x 20 mm
Max. cable weight : 10 kg
Travelling speed : 60 m/min.
Temperatures : min. - 15 °C, max. 180 °C

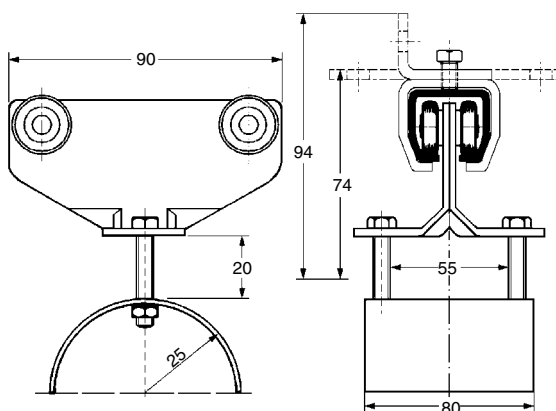

Flat cable towing trolley MVS150

Material : galvanised and dichromated steel
Weight : 0,6 kg
Cable dimensions : 55 x 20 mm
Max. cable weight : 10 kg
Travelling speed : 60 m/min.
Temperatures : min. - 15 °C, max. 180 °C

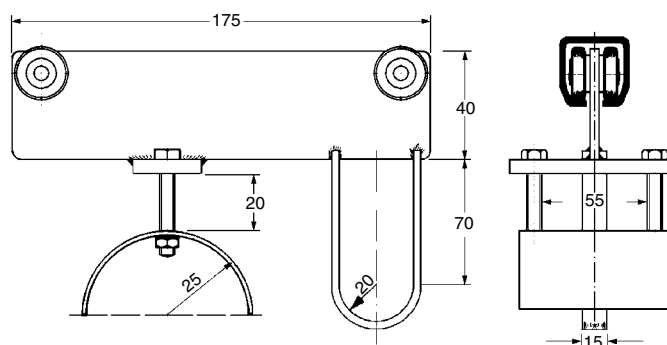

Cable trolleys (steel), for profile R150

For round cables and/or hoses

These AKAPP cable trolleys are suitable for light duty operations. All steel parts are dichromatised, which ensures a long life protection. The high quality steel wheels are double ball beared and have anti dust sealing. The wheels are especially lubricated for a high temperature range. The turnable cable carriers (up to 2 clamp ranges) prevent twisting and tangling of cables and hoses.

The number of cable carriers per trolley is variable. Standard options are trolleys with 1, 2 or 3 carriers. However more carriers or different carrier sizes per trolley are also possible.

Please contact Wabtec Netherlands B.V. if you need more advice.

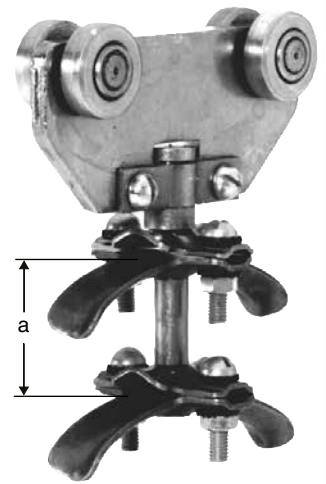

End clamp AR150

Material : galvanised and dichromated steel
 Max. cable weight : 10 kg
 Temperatures : min. - 15 °C, max. 180 °C

Clamp cap. (mm) Ø	h	h ₁	l ₁	b	a	weight (kg) 1 clamp
8-15	73	50	70	40	32	0,15
16-24	78	55	98	50	45	0,2

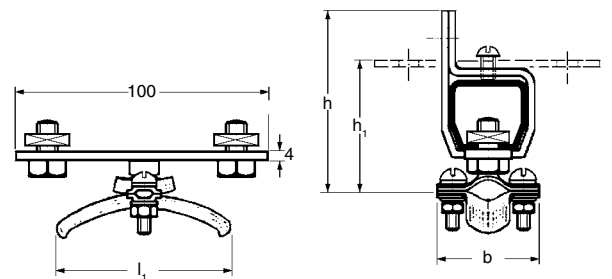

Cable trolley KR150

Material : galvanised and dichromated steel
 Max. cable weight : 10 kg
 Travelling speed : 60 m/min.
 Temperatures : min. - 15 °C, max. 180 °C

Clamp cap. (mm) Ø	h	h ₁	l ₁	b	a	weight (kg) 1 clamp
8-15	91	68	70	40	32	0,26
16-24	121	95	98	50	45	0,31

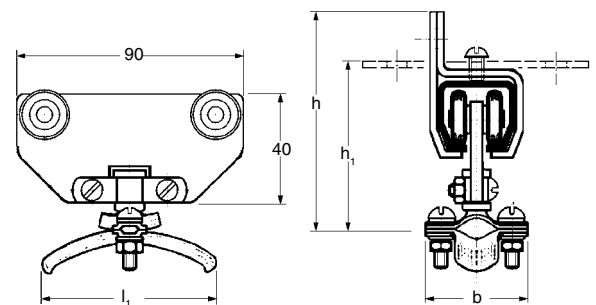

Cable towing trolley MR150

Material : galvanised and dichromated steel
 Max. cable weight : 10 kg
 Travelling speed : 60 m/min.
 Temperatures : min. - 15 °C, max. 180 °C

Clamp cap. (mm) Ø	h	h ₁	l ₁	b	a	weight (kg) 1 clamp
8-15	91	68	70	40	32	0,51
16-24	121	95	98	50	45	0,56

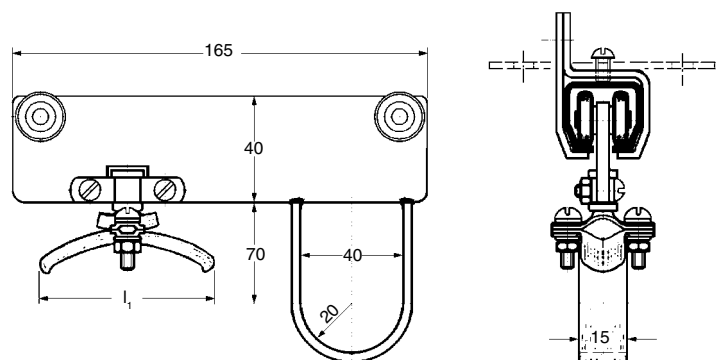

Mobile pendant terminal box for profile R150

AKAPP mobile pendants have been developed specifically for cranes requiring remote pendant control, therefore allowing the crane operator to work from a safe position. Available are:

a. Mobile pendants, standard fitted with terminal box (plastic or steel).

The pendant cable and flat cable(s) can easily be inserted into the entry glands.

Connection by means of individual terminals.

b. Mobile pendants, standard fitted with plug/socket unit.

This simplified and compact pendant unit has been developed for applications up to 24 terminals.

See reverse for details.



Mobile pendant with terminal box, SBWK150G

The box is provided with a cable gland PG48 for the flat cable(s) to enter. A cable gland PG21 at the bottom allows entry for the pendant cable (see mounting diagram below). This is usually a round cable with 2-sided integrated steel wires. A strainer wire termination is included.

The terminal box is connected to the two suspension trolleys by means of swivels. This allows the terminal box to swing without affecting the movement of the trolleys.

This mobile pendant can optionally be fitted with a brake unit, activated by means of a towing chain.

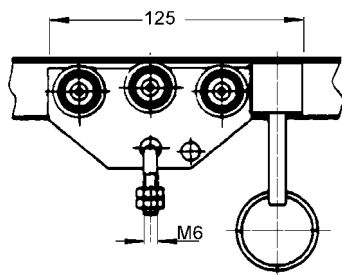
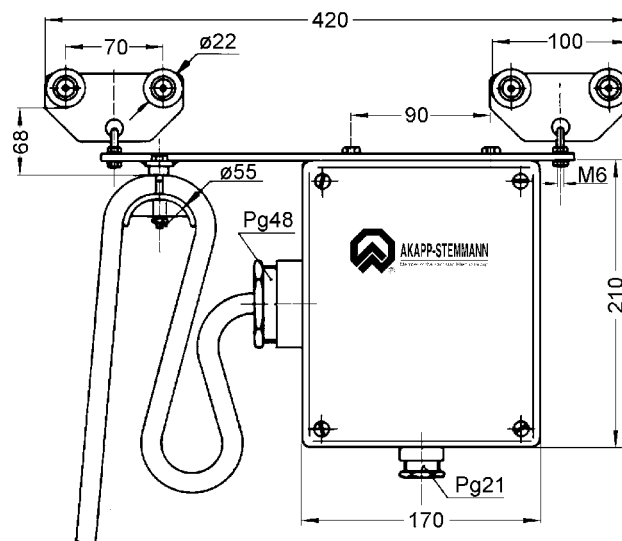

Mounting diagram

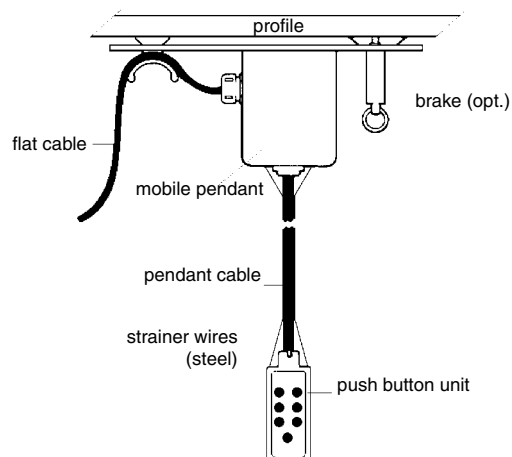

AKAPP Mobile pendants with terminal box are also available for profile R300.

Mobile pendants with plug/socket, SBWS150M

The zinc plated steel chassis is provided with a socket (either 16 or 24 terminals) and a cable gland for flatform cable. This cable can easily be connected to the terminals.

The pendant cable is to be connected to the 16- or 24-pole plug. A terminal for the strainer wires is provided.

Making the connection between the pre-wired plug and socket is fast and easily done. After that, the combination can be double locked to prevent unexpected loosening.

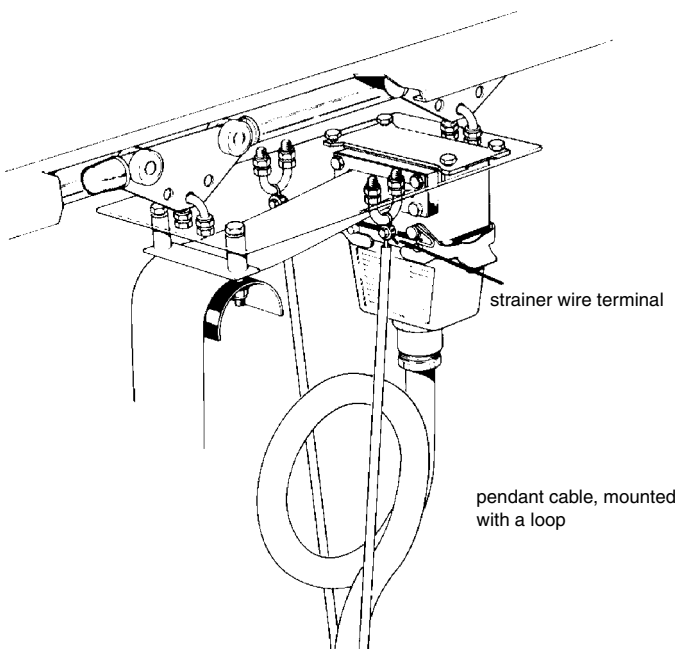

The advantages of AKAPP mobile pendant plug/socket units:

- easy installation
- work more safely because of a better view
- optimal control convenience of your push button unit
- fast and easy exchange of the push button unit
- very solid construction
- with either 16- or 24-pole unit
- available from stocks

Cable trolleys (aluminium), for profile R300

For flat cables



AKAPP aluminium cable trolleys for track profile R300 are especially suited to average sized installations, for both in- and outdoor conditions. The steel wheels are ball beared. The trolleys therefore will roll perfectly smooth through the track profile. The trolleys are equipped with a rubber strip to press against the cable(s).

The cable carriers are equipped with a large radius to prevent the cables from bending too strongly. The cable carrier provides generous space for large cable packets.

End clamp AVK300

Material : mounting plate in galvanised steel
cable carrier in aluminium

Weight : 0,76 kg

Cable dimensions : 89x30 mm max.

Max. cable weight : 40 kg

Temperatures : min. - 5 °C, max. 105 °C

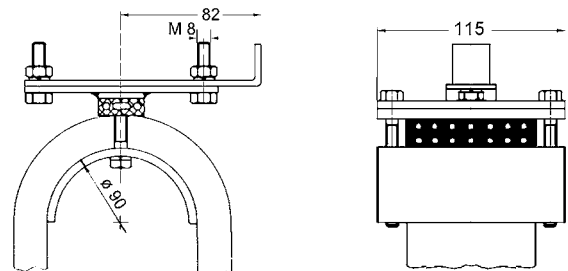

Flat cable trolley KVK300

Material : chassis aluminium
cable carrier in aluminium
wheels steel, ball beared

Weight : 0,65 kg

Cable dimensions : 89 x 30 mm

Max. cable weight : 40 kg

Travelling speed : 120 m/min.

Temperatures : min. - 5 °C, max. 105 °C

(see photo on top)

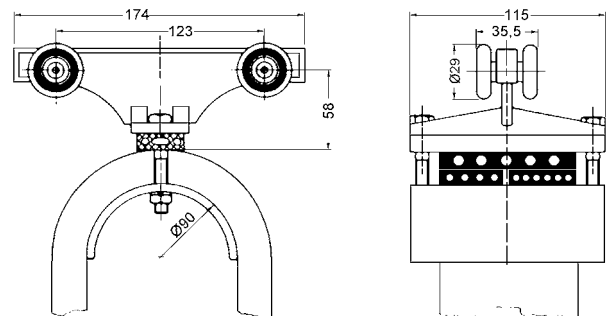

Flat cable towing trolley MVK300

Material : aluminium frame and
cable carrier
wheels steel, ball beared

Weight : 1,17 kg

Cable dimensions : 89x30 mm max.

Cable weight : 40 kg max.

Travelling speed : 120 m/min max.

Temperatures : min. - 5 °C, max. 105 °C

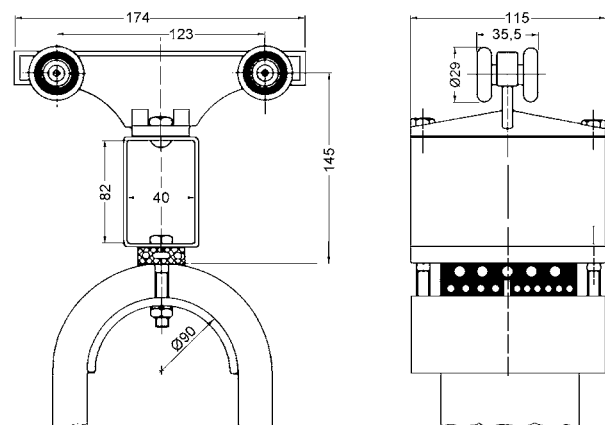

Cable trolleys (steel), for profile R300

For flat cables



AKAPP steel cable trolleys for profile R300 are applicable for medium duty operation, for both in- and outdoor conditions. All steel parts are dichromatised, which ensures a long life protection. The high quality steel wheels are double ball beared and have anti dust sealing. The wheels are especially lubricated for a high temperature range.

This trolley type is standard provided with bumpers and holes for towing chains.

End clamp AVS300

Material : galvanised and dichromated steel
 Max. cable weight : 30 kg
 Temperatures : min. - 15 °C, max. 180 °C

Clamp cap. w x h (mm)	b	c	L	weight (kg)
60 x 40	60	94	150	0,63
125 x 40	125	160	150	0,86

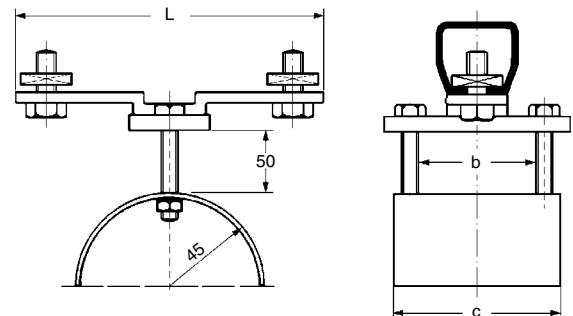

Flat cable trolley KVS300

Material : galvanised and dichromated steel
 Max. cable weight : 30 kg
 Travelling speed : 120 m/min.
 Temperatures : min. - 15 °C, max. 180 °C

Clamp cap. w x h (mm)	b	c	L	weight (kg)
60 x 40	60	94	150	0,8
125 x 40	125	160	180	1,2

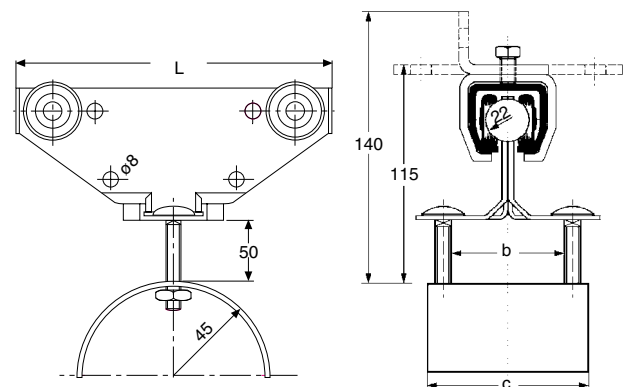

Flat cable towing trolley MVS300

Material : galvanised and dichromated steel
 Max. cable weight : 30 kg
 Travelling speed : 120 m/min.
 Temperatures : min. - 15 °C, max. 180 °C

Clamp cap. w x h (mm)	b	c	L	weight (kg)
60 x 40	60	94	260	1,4
125 x 40	125	160	260	1,6

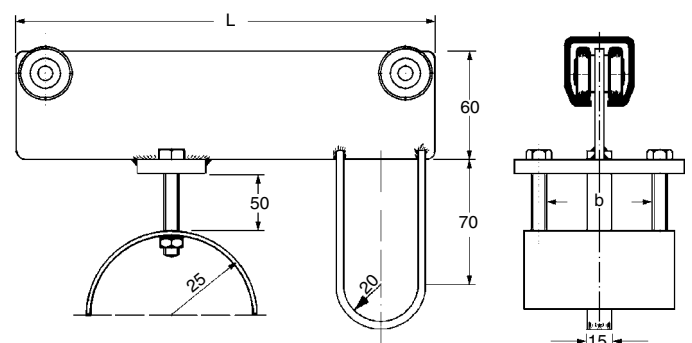

Cable trolleys (steel), for profile R300

For round cables and/or hoses

These AKAPP cable trolleys are suitable for medium duty operations. All steel parts are dichromatised, which ensures a long life protection. The high quality steel wheels are double ball beared and have anti dust sealing. The wheels are especially lubricated for a high temperature range. The turnable cable carriers (up to 4 clamp ranges) prevent twisting and tangling of cables and hoses.

The number of cable carriers per trolley is variable. Standard options are trolleys with 1, 2 or 3 carriers. However more carriers or different carrier sizes per trolley are also possible.

Please contact Wabtec Netherlands B.V. if you need more advice.

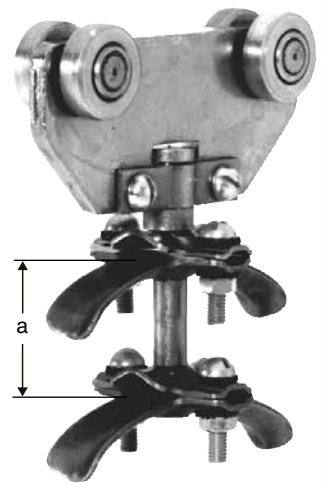

End clamp AR300

Material : galvanised and dichromated steel
 Carrying capacity : 30 kg
 Temperatures : min. -15, max. +180 °C

Clamp cap. (mm) Ø	h	h ₁	l ₁	b	a	weight (kg) 1 clamp
8-15	95	69	70	40	32	0,33
16-24	100	74	98	50	45	0,38
25-32	105	79	142	82	68	0,53
33-43	115	89	175	108	70	1,0

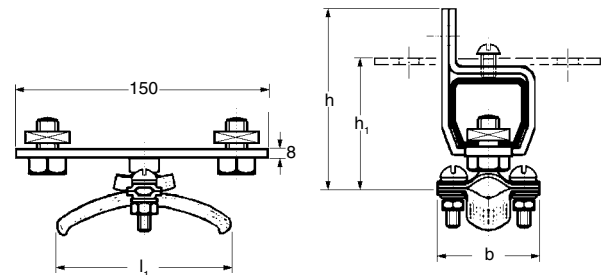

Cable trolley KR300

Material : galvanised and dichromated steel
 Carrying capacity : 30 kg
 Travelling speed : 120 m/min. max.
 Temperatures : min. -15, max. +180 °C

Clamp cap. (mm) Ø	h	h ₁	l ₁	L	b	a	weight (kg) 1 clamp
8-15	116	90	70	100	40	32	0,55
16-24	121	95	98	100	50	45	0,62
25-32	123	97	142	150	82	68	0,85
33-43	130	106	175	150	108	70	1,4

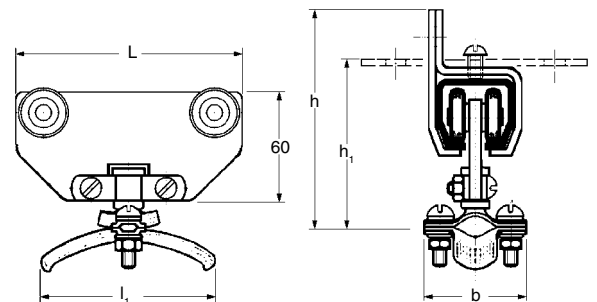

Cable towing trolley MR300

Material : galvanised and dichromated steel
 Carrying capacity : 30 kg
 Travelling speed : 120 m/min. max.
 Temperatures : min. -15, max. +180 °C

Clamp cap. (mm) Ø	h	h ₁	l ₁	L	b	a	weight (kg) 1 clamp
8-15	116	90	70	225	40	32	1,05
16-24	121	95	98	225	50	45	1,1
25-32	123	97	142	225	82	68	1,25
33-43	130	106	175	310	108	70	2,2

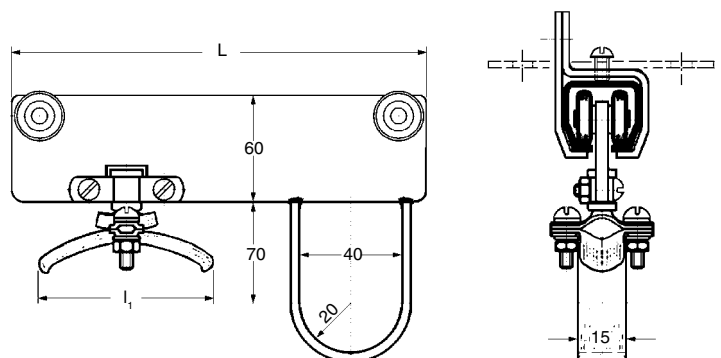

Cable trolleys (steel), for profile R400

For flat cables

AKAPP steel cable trolleys for profile R400 are applicable for heavy duty operation, for both in- and outdoor conditions. The cable clamps are available in 2 widths. All steel parts are dichromatised, which ensures a long life protection.

The high quality steel wheels are double ball beared and have anti dust sealing. The wheels are especially lubricated for a high temperature range.

This trolley type is standard provided with bumpers and holes for towing chains.



End clamp AVS400

Material : galvanised and dichromated steel

Max. cable weight : 50 kg

Temperatures : min. - 15 °C, max. 180 °C

Clamp cap. w x h (mm)	b	c	L	Weight (kg)
80 x 40	80	115	150	0,73
150 x 40	150	185	150	0,97

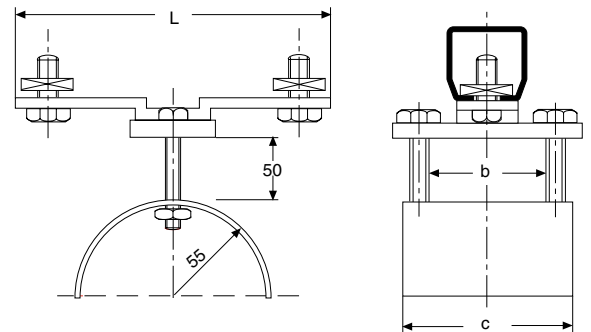

Flat cable trolley KVS400

Material : galvanised and dichromated steel

Max. cable weight : 50 kg

Travelling speed : 180 m/min.

Temperatures : min. - 15 °C, max. 180 °C

Clamp cap. w x h (mm)	b	c	L	Weight (kg)
80 x 40	80	115	180	1,7
150 x 40	150	185	226	1,93

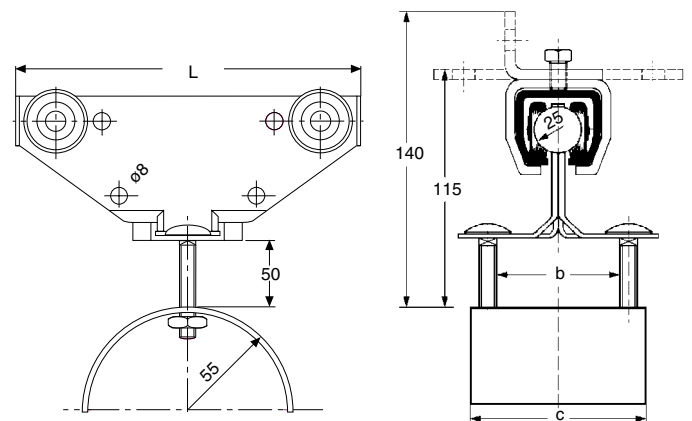

Flat cable towing trolley MVS400

Material : galvanised and dichromated steel

Max. cable weight : 50 kg

Travelling speed : 180 m/min.

Temperatures : min. - 15 °C, max. 180 °C

Clamp cap. w x h (mm)	b	c	L	Weight (kg)
80 x 40	80	115	260	1,6
150 x 40	150	185	260	2,0

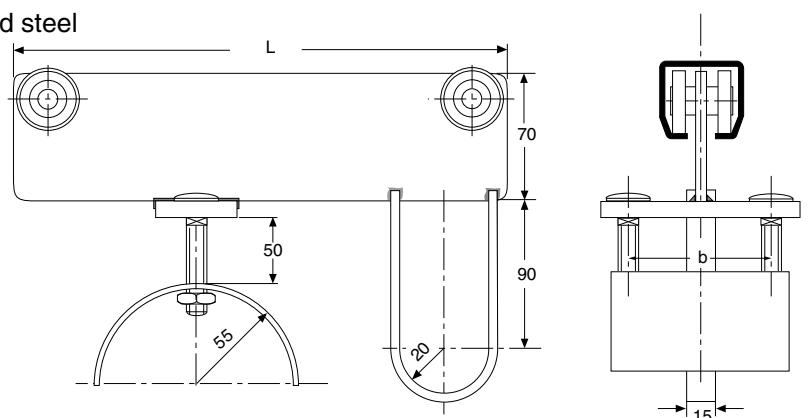

Cable trolleys (steel), for profile R400

For round cables and/or hoses

These AKAPP cable trolleys are suitable for heavy duty operations. All steel parts are dichromatised, which ensures a long life protection. The high quality steel wheels are double ball beared and have anti dust sealing. The wheels are especially lubricated for a high temperature range. The turnable cable carriers (up to 5 clamp ranges) prevent twisting and tangling of cables and hoses.

The number of cable carriers per trolley is variable. Standard options are trolleys with 1, 2 or 3 carriers. However more carriers or different carrier sizes per trolley are also possible.

Please contact Wabtec Netherlands B.V. if you need more advice.

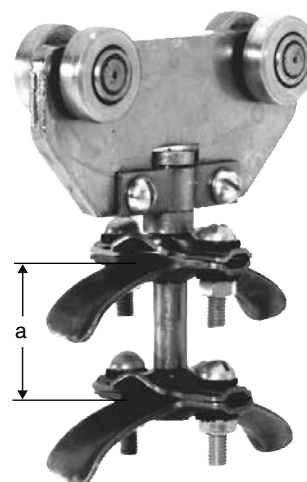

End clamp AR400

Material : galvanised and dichromated steel

Carrying capacity : 50 kg

Temperatures : min. -15, max. +180 °C

Clamp cap. (mm) Ø	h	h ₁	l ₁	b	a	weight (kg) 1 clamp
8-15	114	79	70	40	32	0,33
16-24	119	84	98	50	45	0,38
25-32	125	90	142	82	68	0,53
33-43	135	100	175	108	70	1
44-60	145	110	245	128	90	1,8

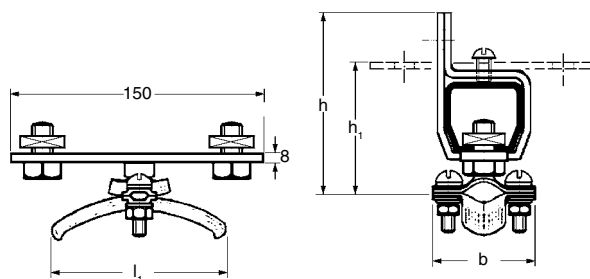

Cable trolley KR400

Material : galvanised and dichromated steel

Carrying capacity : 30 kg

Travelling speed : 180 m/min. max.

Temperatures : min. -15, max. +180 °C

Clamp cap. (mm) Ø	h	h ₁	l ₁	L	b	a	weight (kg) 1 clamp
8-15	140	104	70	100	40	32	0,7
16-24	142	106	98	100	50	45	0,75
25-32	148	112	142	150	82	68	1
33-43	158	122	175	150	108	70	1,6
44-60	164	128	245	150	128	90	2,5

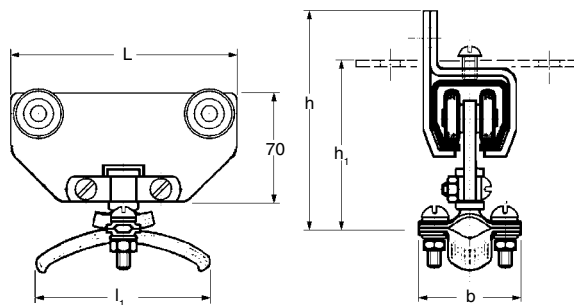

Cable towing trolley MR400

Material : galvanised and dichromated steel

Carrying capacity : 50 kg

Travelling speed : 180 m/min. max.

Temperatures : min. -15, max. +180 °C

Clamp cap. (mm) Ø	h	h ₁	l ₁	L	b	a	weight (kg) 1 clamp
8-15	116	90	70	225	40	32	1,25
16-24	121	95	98	225	50	45	1,35
25-32	123	97	142	225	82	68	1,45
33-43	130	106	175	310	108	70	2,4
44-60	164	128	245	310	128	90	3,3

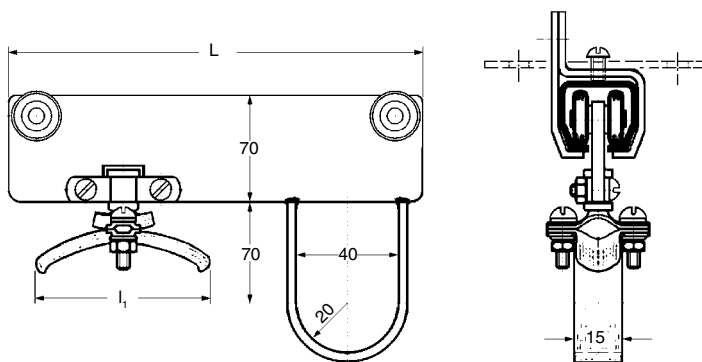

*All dimensions in this brochure are in mm unless otherwise estated.
All dimensions and performances are under proviso .*

Wabtec Netherlands: Flexible with energy!



Wabtec Netherlands is a market leader with our made to order conductor bar systems. We offer you the best possible solution for almost any application in whatever the circumstances. Multipole and single pole systems available. We welcome your inquiries!



Our festoon systems offer the most flexible solutions for transporting flat or round cables and hoses. A wide variety of profiles and components guarantees reliable installations, adapted to the environment.



The AKAPP products are designed by the highest standards and are certified by UL, CCC and CE.

More information on our products can be found in our brochures, which we are happy to send you on request. Or visit our website www.akapp.com, where you can find more relevant information, download brochures and make online inquiries; fast and easy!